

Studer Digital DSP Telephone Hybrid

For an intelligible link ...

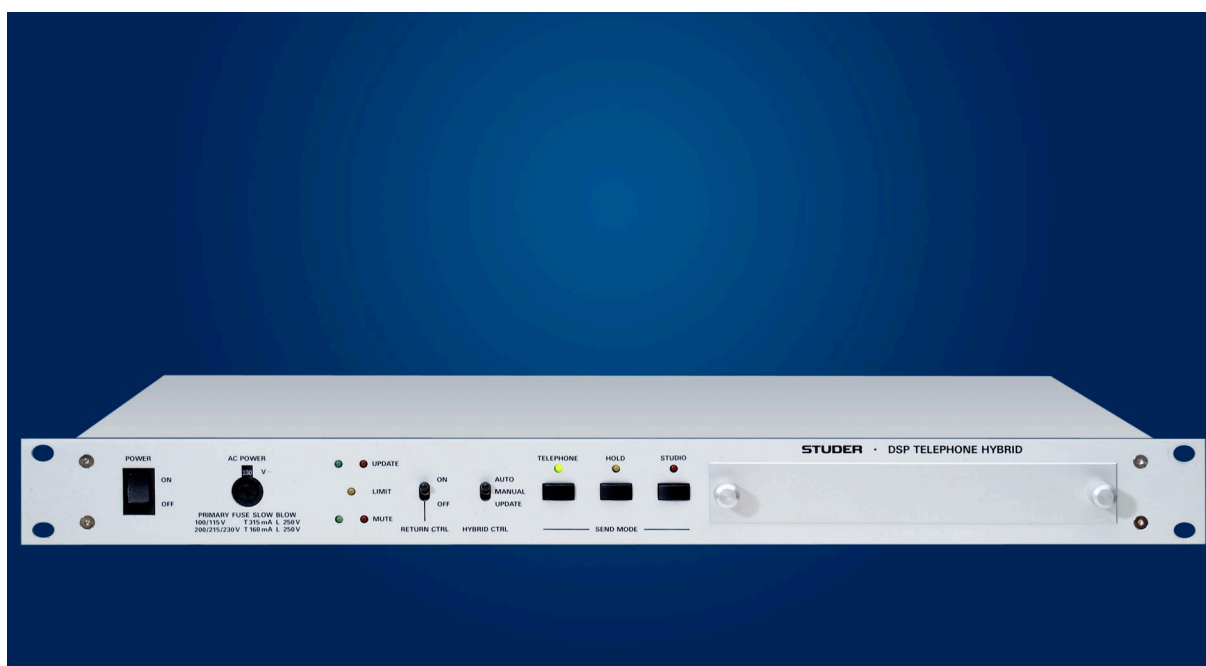

State of the art

For inserting telephone conversations into a radio program, special interfaces are required to adapt the signal supplied by 2-wire telephone lines to the mixing desk. On the studio side, these interfaces appear as a dual line amplifier, while on the telephone network side they behave like a regular handset; for this reason such units are often referred to as telephone hybrids.

A complex resistance is used for impedance matching with the telephone line. The better the match, the better the suppression of crosstalk between the transmit and receive sides.

In today's state of the art, line impedance matching is usually performed automatically. However, the match is exact at only a few points of the frequency spectrum, which means that small discrepancies remain. The existing technology is nevertheless satisfactory for handling direct lines with widely differing lengths and characteristics.

The nature of telephone trunks has changed significantly in recent years. The introduction of carrier frequency lines and glass fibre cables between exchanges frequently reduces the length of direct lines to just a few kilometres. Since radio studios are usually located in large cities, the distance to the first converter is often very short. For this reason, the effectiveness of conventional hybrid circuits is frequently limited to the local lines only.

Digital filters

Modern signal processors make it possible to implement echo suppression circuits using digital filters. The algorithms used are effective beyond the local exchange lines and are able to suppress echoes that originate from a long-distance subscriber and are transmitted through telephone trunk circuits.

The principal distinction between analogue and digital hybrids is that analogue units counteract a specific cause of line echo (by adaptive matching), while digital units suppress the echo itself (by appropriate filtering). The latter approach makes the actual cause of the echo irrelevant.

- Digital telephone hybrid with self-converging filter algorithms for suppressing line echoes
- Excellent results thanks to numerous coefficients
- Manual or automatic echo suppression matching
- Additional echo suppression in the studio loop
- Switchable to 4-wire applications such as ISDN connections or general echo suppression

... between the presenter and the listener

Studer digital telephone hybrid

The block diagram shows two symmetrically arranged functional blocks, each one implemented using a TMS 320 microprocessor. By comparing the send and receive signals, the signal processor [C] detects peaks in the frequency response caused by echoes and re-adjusts the filter [F] so as to make them disappear. The accuracy of this process depends on the number of filter coefficients. The Studer hybrid is very powerful, with 128 coefficients on the telephone side and 96 on the studio side.

The right-hand block suppresses echoes on the telephone line. A fixed bridge circuit with nominal termination impedances is used for coarse line adaptation. It provides first-stage echo suppression and considerably reduces the time required for the subsequent convergence process.

The left-hand block (with 96 coefficients) is used for echo suppression in the studio; it reduces feedback between the presenter's headphones and microphone. This kind of feedback is likely to occur when a weak caller signal necessitates a strong gain increase in the receive path. Echo suppression is so efficient that it is even possible to insert telephone conversations through loudspeakers. Both

signal processors function independently of each other. Filter optimisation is either continuous and automatic under signal conditions (thereby also correcting for feedback changes caused for example by the presenter's body movements), or a one-time manually initiated sequence that analyses a transmitted noise burst lasting less than one second.

The digital telephone hybrid can be used in "radio" or "TV" mode. In "radio" mode, the presenter talks to the calling party through the on-air microphone and listens through headphones or a loudspeaker. In "TV" mode, the presenter talks to the calling party using a telephone handset, while the program (and the reference signal input for the telephone hybrid) comes via an out-of-vision microphone.

Dial and ring tones can either be passed through, or suppressed. The digital telephone hybrid can also be switched to 4-wire mode, which makes 240 coefficients available. This means the unit is suitable not only for a wide range of ISDN applications, but also for general echo suppression tasks.

The single-channel digital telephone hybrid with integral power supply unit is packaged in a 1U 19" rack-mount housing.

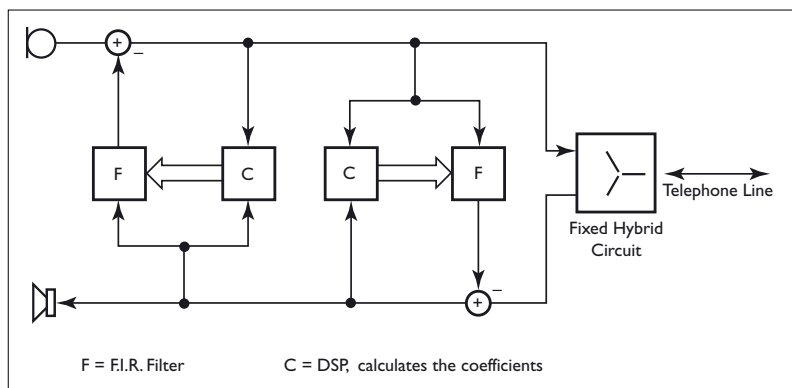

STUDER
professional audio equipment

H A Harman International Company

Studer Professional Audio GmbH Althardstrasse 30, CH-8105 Regensdorf-Zurich Switzerland, Phone +41 44 870 75 11, Fax +41 44 870 71 34

www.studer.ch

Subject to change. Studer is a registered trademark of Studer Professional Audio GmbH. Printed in Switzerland. Copyright by Studer Professional Audio GmbH